



The world leader in electric fireplaces.

# 50" Linear Electric Firebox

BLF50

## Product Description

- Patented electric flame technology
- Flame bed made from glass pieces that are colored and silvered on one side
- Light shines and reflects off the randomly-sized glass pieces creating an effect that is as alluring as it is contemporary.
- Four installation options:
  - Fully recessed in to a new construction wall
  - Retrofit – built-in to an existing 2x4 wall
  - Wall-mount
  - Installed as part of Dimplex mantel packages
- Operates with flame only or flame and heat
- Built-in manual switches – main on/off, low heat (600 Watts), high heat (1200 Watts).
- 120 Volts / 1,230 Watts / 4,198 BTU

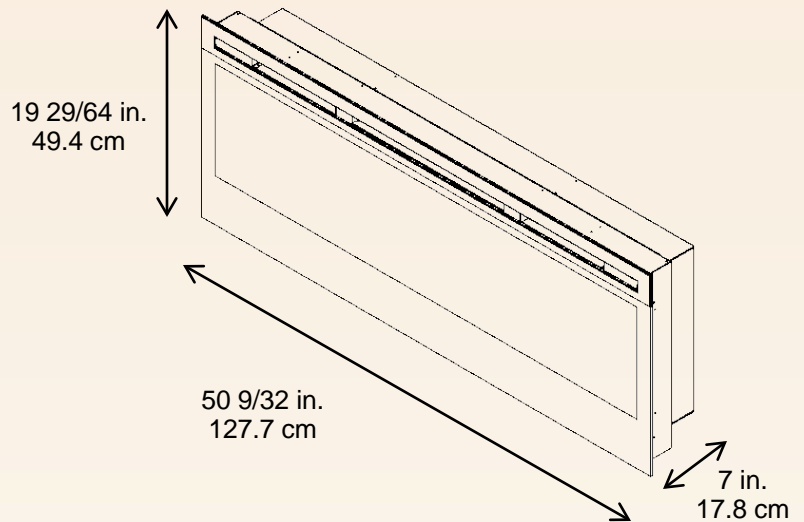

Includes 3-stage remote control

Model #	Description	lbs / kg	UPC	Wty. <sup>†</sup>	Carton Dimensions (W x H x D)		Cube	
					Inches	cm	ft <sup>3</sup>	m <sup>3</sup>
BLF50	50" built-in electric firebox	80 / 36.3	781052 061149	2 yr	54.7 x 12.5 x 22	139 x 32 x 56	8.7	0.25
Accessories (Optional): WRCPF-KIT Wall switch remote control								

Specifications, finishes and dimensions are subject to change. Patent protected: for a complete list of applicable patents visit [www.dimplex.com/patents](http://www.dimplex.com/patents).  
 \*Based on average national residential electricity rates. Rates vary. <sup>†</sup>Limited warranty © 2010 Dimplex North America Limited.